

**Rubycon** **大形アルミニウム電解コンデンサ** **USR**  
**LARGE CAN TYPE ALUMINUM ELECTROLYTIC CAPACITORS**

**USR** シリーズ  
SERIES

**旧シリーズ**



基板自立形85 標準品  
 85 Standard, Snap-in Terminal Type

**特長 FEATURES**

- 85 3000時間品。  
 Load Life : 85 3000 hours.
- 従来のUSRシリーズを更に小形化・高リップル化。  
 Smaller size with higher ripple current endurance than USP series.

**規格表 SPECIFICATIONS**

項目 Items	特性 Characteristics																									
カテゴリ温度範囲 Category Temperature Range	- 40 ~ + 85	- 25 ~ + 85																								
定格電圧範囲 Rated Voltage Range	10 ~ 250V.DC	315 ~ 450V.DC																								
静電容量許容差 Capacitance Tolerance	± 20% ( 20 , 120Hz )																									
漏れ電流 Leakage Current(MAX)	$I = 3\sqrt{CV}$ ( 定格電圧印加5分後 ) $I = 3\sqrt{CV}$ ( After 5 minutes application of rated voltage ) I = 漏れ電流( µ A )      V = 定格電圧(V)      C = 定格静電容量( µ F ) Leakage Current      Rated Voltage      Rated Capacitance																									
損失角の正接 (tan ) Dissipation Factor(MAX)	<table border="1"> <tr> <td>定格電圧(V) Rated Voltage</td> <td>10</td> <td>16</td> <td>25</td> <td>35</td> <td>50</td> <td>63</td> <td>80</td> <td>100</td> <td>160~ 400</td> <td>420~ 450</td> <td>( 20 , 120Hz )</td> </tr> <tr> <td>tan</td> <td>0.55</td> <td>0.50</td> <td>0.45</td> <td>0.40</td> <td>0.35</td> <td>0.30</td> <td>0.25</td> <td>0.20</td> <td>0.15</td> <td>0.25</td> <td></td> </tr> </table>		定格電圧(V) Rated Voltage	10	16	25	35	50	63	80	100	160~ 400	420~ 450	( 20 , 120Hz )	tan	0.55	0.50	0.45	0.40	0.35	0.30	0.25	0.20	0.15	0.25	
定格電圧(V) Rated Voltage	10	16	25	35	50	63	80	100	160~ 400	420~ 450	( 20 , 120Hz )															
tan	0.55	0.50	0.45	0.40	0.35	0.30	0.25	0.20	0.15	0.25																
インピーダンス比 Impedance Ratio(MAX)	<table border="1"> <tr> <td>定格電圧(V) Rated Voltage</td> <td>10 ~ 250</td> <td>315 ~ 400</td> <td>420 ~ 450</td> <td>( 120Hz )</td> </tr> <tr> <td>Z (-25 YZ 20 )</td> <td>3</td> <td>4</td> <td>12</td> <td></td> </tr> <tr> <td>Z (-40 YZ 20 )</td> <td>12</td> <td></td> <td></td> <td></td> </tr> </table>		定格電圧(V) Rated Voltage	10 ~ 250	315 ~ 400	420 ~ 450	( 120Hz )	Z (-25 YZ 20 )	3	4	12		Z (-40 YZ 20 )	12												
定格電圧(V) Rated Voltage	10 ~ 250	315 ~ 400	420 ~ 450	( 120Hz )																						
Z (-25 YZ 20 )	3	4	12																							
Z (-40 YZ 20 )	12																									
耐久性 Endurance	85 中で3000時間定格電圧(リップル重畳)印加後、下記項目を満足すること After applying rated voltage with rated ripple current for 3000hrs at 85 , the capacitors shall meet the following requirements. <table border="1"> <tr> <td>静電容量変化率 Capacitance Change</td> <td>初期値の±20%以内 Within ±20% of the initial value.</td> </tr> <tr> <td>損失角の正接 Dissipation Factor</td> <td>規格値の200%以下 Not more than 200% of the specified value.</td> </tr> <tr> <td>漏れ電流 Leakage Current</td> <td>規格値以下 Not more than the specified value.</td> </tr> </table>		静電容量変化率 Capacitance Change	初期値の±20%以内 Within ±20% of the initial value.	損失角の正接 Dissipation Factor	規格値の200%以下 Not more than 200% of the specified value.	漏れ電流 Leakage Current	規格値以下 Not more than the specified value.																		
静電容量変化率 Capacitance Change	初期値の±20%以内 Within ±20% of the initial value.																									
損失角の正接 Dissipation Factor	規格値の200%以下 Not more than 200% of the specified value.																									
漏れ電流 Leakage Current	規格値以下 Not more than the specified value.																									

**リップル電流補正係数 MULTIPLIER FOR RIPPLE CURRENT**

周波数係数 Frequency coefficient

周波数(Hz) Frequency	60( 50 )	120	500	1k	10k
10 ~ 100WV	0.90	1.00	1.05	1.10	1.15
160 ~ 250WV	0.80	1.00	1.20	1.30	1.50
315 ~ 450WV	0.80	1.00	1.05	1.10	1.15

**呼称方法 PART NUMBER**

USR		OOE		D x L		
定格電圧 Rated Voltage	シリーズ名 Series	定格静電容量 Rated Capacitance	静電容量許容差 Capacitance Tolerance	副記号 Option	端子記号 Terminal Code	ケースサイズ Case Size

**副記号 Option**

	記号 Code
底板なし without plate	OOE
底板あり with plate	なし Blank



# 大形アルミニウム電解コンデンサ

## LARGE CAN TYPE ALUMINUM ELECTROLYTIC CAPACITORS

USR

### 寸法図 DIMENSIONS (mm)

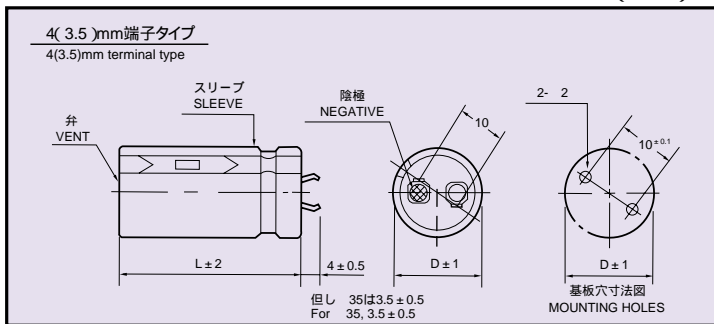

### 寸法一覧表, 定格リップル電流一覧表 STANDARD SIZE, RATED RIPPLE CURRENT

Cap (μF)	WV D	10					16					
		20	22	25	30	35	20	22	25	30	35	
6800							20×25; 2.33					
8200							20×30; 2.56	22×25; 2.56				
10000		20×25; 2.22					20×35; 2.85	22×30; 2.81				
12000		20×30; 2.44	22×25; 2.41				20×40; 3.20	22×30; 3.13	25×25; 2.96			
15000		20×35; 2.90	22×30; 2.88	25×25; 2.88				22×35; 3.69	25×30; 3.64	30×25; 3.73		
18000		20×40; 3.31	22×35; 3.22	25×30; 3.08				22×40; 3.98	25×35; 3.98	30×30; 3.88		
22000			22×40; 3.79	25×30; 3.66	30×25; 3.53			22×50; 4.52	25×40; 4.44	30×30; 4.38		
27000			22×45; 4.04	25×35; 4.04	30×30; 3.99				25×45; 4.98	30×35; 4.82	35×30; 4.82	
33000			22×50; 4.58	25×40; 4.56	30×30; 4.58				25×50; 5.49	30×40; 5.38	35×35; 5.33	
39000				25×45; 5.29	30×35; 5.21	35×30; 5.05				30×45; 6.11	35×35; 6.01	
47000				25×50; 5.78	30×40; 5.78	35×35; 5.55				30×50; 6.80	35×40; 6.80	
56000					30×45; 6.59	35×35; 6.40					35×45; 7.62	
68000					30×50; 7.50	35×40; 7.48						
82000						35×50; 8.50						

Cap (μF)	WV D	25					35					
		20	22	25	30	35	20	22	25	30	35	
2700							20×25; 1.76					
3300							20×30; 2.14					
3900							20×30; 2.28	22×25; 2.22				
4700		20×25; 2.18					20×35; 2.46	22×30; 2.46	25×25; 2.43			
5600		20×30; 2.33	22×25; 2.31					22×35; 2.79	25×30; 2.75			
6800		20×35; 2.56	22×30; 2.56					22×40; 2.89	25×30; 2.89	30×25; 3.09		
8200		20×40; 2.91	22×35; 2.81	25×25; 2.78				22×45; 3.47	25×35; 3.33	30×30; 3.29		
10000			22×35; 3.18	25×30; 3.16				22×50; 3.59	25×40; 3.59	30×30; 3.61		
12000			22×40; 3.53	25×35; 3.48	30×25; 3.53				25×45; 4.01	30×35; 4.01	35×30; 4.02	
15000			22×50; 4.08	25×40; 4.00	30×30; 4.00					30×40; 4.80	35×35; 4.80	
18000				25×45; 4.68	30×35; 4.66	35×30; 4.68				30×45; 5.18	35×40; 5.71	
22000					30×40; 5.19	35×35; 5.20					35×45; 6.38	
27000					30×45; 6.02	35×40; 6.02					35×50; 6.90	
33000						35×45; 6.75						
39000						35×50; 7.56						

Cap (μF)	WV D	50					63					
		20	22	25	30	35	20	22	25	30	35	
1500							20×25; 1.69					
1800		20×25; 1.70					20×30; 2.04	22×25; 1.90				
2200		20×30; 2.07	22×25; 1.93				20×35; 2.40	22×30; 2.35	25×25; 2.30			
2700		20×35; 2.21	22×30; 2.21				20×40; 2.52	22×35; 2.50	25×30; 2.49			
3300		20×40; 2.41	22×30; 2.41	25×25; 2.38				22×40; 2.69	25×30; 2.69	30×25; 2.78		
3900			22×35; 2.72	25×30; 2.68				22×45; 3.10	25×35; 3.09	30×30; 3.09		
4700			22×40; 3.01	25×30; 3.03	30×25; 3.01			22×50; 3.49	25×40; 3.37	30×30; 3.37		
5600			22×45; 3.43	25×35; 3.37	30×30; 3.43				25×45; 3.80	30×35; 3.81	35×30; 3.75	
6800			22×50; 3.94	25×40; 3.87	30×35; 3.87				25×50; 4.41	30×40; 4.41	35×35; 4.33	
8200				25×45; 4.37	30×35; 4.42	35×30; 4.41				30×45; 4.90	35×35; 4.80	
10000					30×40; 5.02	35×35; 4.92				30×50; 5.49	35×40; 5.47	
12000					30×50; 5.60	35×40; 5.60					35×50; 6.30	
15000						35×45; 6.44						
18000						35×50; 6.71						

↑ ↑ リプル電流 Ripple Current A r.m.s./120Hz-85  
↑ ケースサイズ Case Size D<sup>±1</sup> × L<sup>±2</sup>(mm)



# 大形アルミニウム電解コンデンサ

## LARGE CAN TYPE ALUMINUM ELECTROLYTIC CAPACITORS

USR

寸法一覧表, 定格リップル電流一覧表 STANDARD SIZE, RATED RIPPLE CURRENT

Cap ( $\mu$ F)	WV D	80					100				
		20	22	25	30	35	20	22	25	30	35
680							20 x 25; 1.66				
820							20 x 30; 1.85	22 x 25; 1.86			
1000		20 x 25; 1.56					20 x 35; 2.02	22 x 30; 2.02			
1200		20 x 30; 1.80	22 x 25; 1.77				20 x 40; 2.12	22 x 30; 2.12	25 x 25; 2.10		
1500		20 x 35; 2.10	22 x 30; 2.01					22 x 35; 2.45	25 x 30; 2.43		
1800		20 x 40; 2.30	22 x 35; 2.25	25 x 25; 2.26				22 x 40; 2.77	25 x 35; 2.77	30 x 25; 2.65	
2200			22 x 40; 2.53	25 x 30; 2.53	30 x 25; 2.50			22 x 45; 3.12	25 x 40; 3.20	30 x 30; 3.10	
2700			22 x 45; 2.93	25 x 35; 2.93	30 x 30; 2.91				25 x 45; 3.61	30 x 35; 3.60	35 x 30; 3.71
3300			22 x 50; 3.25	25 x 40; 3.25	30 x 30; 3.23				25 x 50; 4.06	30 x 40; 4.05	35 x 35; 4.07
3900				25 x 45; 3.62	30 x 35; 3.62					30 x 45; 4.60	35 x 35; 4.50
4700				25 x 50; 4.28	30 x 40; 4.15	35 x 30; 4.10				30 x 50; 5.13	35 x 40; 5.12
5600					30 x 45; 4.55	35 x 35; 4.51					35 x 45; 5.75
6800					30 x 50; 5.18	35 x 40; 5.14					35 x 50; 6.01
8200						35 x 45; 5.83					

Cap ( $\mu$ F)	WV D	160					180				
		20	22	25	30	35	20	22	25	30	35
270		20 x 25; 1.22					20 x 25; 1.23				
330		20 x 30; 1.48					20 x 30; 1.48	22 x 25; 1.42			
390		20 x 30; 1.55	22 x 25; 1.55				20 x 30; 1.58	22 x 30; 1.61			
470		20 x 35; 1.81	22 x 30; 1.77	25 x 25; 1.77			20 x 35; 1.82	22 x 30; 1.80	25 x 25; 1.80		
560		20 x 40; 2.04	22 x 35; 2.05	25 x 30; 2.05			20 x 40; 2.04	22 x 35; 2.09	25 x 30; 2.05		
680			22 x 40; 2.24	25 x 30; 2.22	30 x 25; 2.22			22 x 40; 2.36	25 x 35; 2.34	30 x 25; 2.27	
820			22 x 45; 2.55	25 x 35; 2.52	30 x 30; 2.51			22 x 45; 2.72	25 x 35; 2.58	30 x 30; 2.56	
1000			22 x 50; 2.88	25 x 40; 2.86	30 x 30; 2.82				25 x 45; 2.91	30 x 35; 2.95	
1200				25 x 45; 3.27	30 x 35; 3.25	35 x 30; 3.24			25 x 50; 3.46	30 x 40; 3.38	35 x 30; 3.32
1500					30 x 40; 3.77	35 x 35; 3.75				30 x 45; 3.90	35 x 35; 3.83
1800					30 x 45; 4.10	35 x 35; 4.08				30 x 50; 4.33	35 x 40; 4.32
2200						35 x 45; 4.72					35 x 45; 4.60
2700						35 x 50; 5.30					35 x 50; 5.05

Cap ( $\mu$ F)	WV D	200					220				
		20	22	25	30	35	20	22	25	30	35
180							20 x 25; 1.09				
220		20 x 25; 1.13					20 x 30; 1.15	22 x 25; 1.09			
270		20 x 30; 1.32	22 x 25; 1.30				20 x 30; 1.38	22 x 25; 1.31			
330		20 x 30; 1.49	22 x 25; 1.44				20 x 35; 1.51	22 x 30; 1.58	25 x 25; 1.49		
390		20 x 35; 1.66	22 x 30; 1.65	25 x 25; 1.63			20 x 40; 1.73	22 x 35; 1.69	25 x 30; 1.71		
470		20 x 40; 1.93	22 x 35; 1.88	25 x 30; 1.86				22 x 40; 1.99	25 x 30; 1.95	30 x 25; 1.89	
560			22 x 40; 2.08	25 x 30; 2.05	30 x 25; 2.05			22 x 45; 2.28	25 x 35; 2.22	30 x 30; 2.19	
680			22 x 45; 2.36	25 x 35; 2.36	30 x 30; 2.36			22 x 50; 2.46	25 x 40; 2.40	30 x 30; 2.39	
820			22 x 50; 2.68	25 x 40; 2.66	30 x 30; 2.62				25 x 45; 2.81	30 x 35; 2.70	35 x 30; 2.62
1000				25 x 45; 3.12	30 x 35; 3.00	35 x 30; 2.96			25 x 50; 3.13	30 x 40; 3.08	35 x 35; 3.05
1200				25 x 50; 3.44	30 x 40; 3.44	35 x 35; 3.40				30 x 45; 3.60	35 x 40; 3.51
1500					30 x 50; 3.93	35 x 40; 3.87					35 x 45; 3.92
1800						35 x 45; 4.37					
2200						35 x 50; 5.00					

Cap ( $\mu$ F)	WV D	250					315				
		20	22	25	30	35	20	22	25	30	35
120											
150							20 x 30; 0.95				
180		20 x 25; 1.14					20 x 35; 1.08	22 x 30; 1.23	25 x 25; 1.31		
220		20 x 30; 1.20	22 x 25; 1.18				20 x 40; 1.23	22 x 35; 1.34	25 x 30; 1.40		
270		20 x 30; 1.35	22 x 30; 1.43					22 x 40; 1.60	25 x 30; 1.62		
330		20 x 35; 1.60	22 x 30; 1.58	25 x 25; 1.53				22 x 45; 1.82	25 x 35; 1.85	30 x 30; 1.89	
390		20 x 40; 1.83	22 x 35; 1.79	25 x 30; 1.79				22 x 50; 1.97	25 x 40; 2.01	30 x 30; 2.05	
470			22 x 40; 2.05	25 x 35; 2.05	30 x 25; 1.94				25 x 45; 2.20	30 x 35; 2.27	35 x 30; 2.25
560			22 x 45; 2.36	25 x 35; 2.24	30 x 30; 2.24					30 x 40; 2.50	35 x 35; 2.56
680				25 x 40; 2.54	30 x 35; 2.58					30 x 45; 2.67	35 x 40; 2.90
820				25 x 50; 2.87	30 x 35; 2.84	35 x 30; 2.82				30 x 50; 3.12	35 x 45; 3.29
1000					30 x 45; 3.39	35 x 35; 3.31					35 x 50; 3.40
1200					30 x 50; 3.80	35 x 40; 3.66					
1500						35 x 45; 4.12					
1800						35 x 50; 4.31					

↑ ↑ リップル電流 Ripple Current A r.m.s./120Hz-85  
 ケースサイズ Case Size D<sup>±1</sup> x L<sup>±2</sup>(mm)



# 大形アルミニウム電解コンデンサ

## LARGE CAN TYPE ALUMINUM ELECTROLYTIC CAPACITORS

USR

寸法一覧表, 定格リップル電流一覧表 STANDARD SIZE, RATED RIPPLE CURRENT

Cap ( $\mu$ F)	350					385				
	20	22	25	30	35	20	22	25	30	35
68						20 x 25; 0.60				
82						20 x 30; 0.67	22 x 25; 0.70			
100						20 x 30; 0.80	22 x 30; 0.82			
120	20 x 30; 0.91	22 x 25; 0.99				20 x 35; 0.89	22 x 30; 0.91	25 x 25; 0.95		
150	20 x 35; 1.05	22 x 30; 1.14	25 x 25; 1.16			20 x 40; 1.05	22 x 35; 1.04	25 x 30; 1.08		
180	20 x 40; 1.18	22 x 35; 1.28	25 x 30; 1.30				22 x 40; 1.18	25 x 35; 1.20	30 x 25; 1.28	
220		22 x 40; 1.40	25 x 35; 1.46	30 x 25; 1.47			22 x 45; 1.33	25 x 35; 1.44	30 x 30; 1.40	
270		22 x 45; 1.62	25 x 35; 1.65	30 x 30; 1.71				25 x 40; 1.56	30 x 35; 1.62	
330		22 x 50; 1.78	25 x 40; 1.88	30 x 35; 1.93				25 x 50; 1.80	30 x 40; 1.85	35 x 30; 1.85
390			25 x 45; 2.04	30 x 35; 2.12	35 x 30; 2.19				30 x 40; 2.04	35 x 35; 2.06
470				30 x 40; 2.41	35 x 35; 2.43				30 x 50; 2.27	35 x 40; 2.30
560				30 x 45; 2.60	35 x 35; 2.62					35 x 45; 2.57
680					35 x 40; 3.00					35 x 50; 2.80
820					35 x 50; 3.30					

Cap ( $\mu$ F)	400					420				
	20	22	25	30	35	20	22	25	30	35
68	20 x 25; 0.71					20 x 25; 0.65				
82	20 x 30; 0.78	22 x 25; 0.80				20 x 30; 0.73	22 x 25; 0.75			
100	20 x 30; 0.90	22 x 30; 0.94				20 x 35; 0.85	22 x 30; 0.87	25 x 25; 0.92		
120	20 x 35; 1.02	22 x 30; 1.04	25 x 25; 1.08			20 x 35; 0.99	22 x 30; 1.01	25 x 25; 1.03		
150	20 x 40; 1.16	22 x 35; 1.18	25 x 30; 1.21			20 x 45; 1.15	22 x 35; 1.19	25 x 30; 1.19	30 x 25; 1.14	
180		22 x 40; 1.34	25 x 35; 1.37	30 x 25; 1.45			22 x 45; 1.36	25 x 35; 1.37	30 x 25; 1.35	
220		22 x 45; 1.50	25 x 35; 1.56	30 x 30; 1.58			22 x 50; 1.69	25 x 40; 1.58	30 x 30; 1.56	
270			25 x 40; 1.70	30 x 35; 1.73				25 x 45; 1.83	30 x 35; 1.72	35 x 30; 1.76
330			25 x 50; 1.90	30 x 40; 1.95	35 x 30; 1.95			25 x 50; 2.18	30 x 40; 1.98	35 x 35; 2.04
390				30 x 40; 2.15	35 x 35; 2.17				30 x 45; 2.34	35 x 35; 2.26
470				30 x 50; 2.39	35 x 40; 2.42				30 x 50; 2.67	35 x 40; 2.60
560					35 x 45; 2.71					35 x 45; 2.93
680					35 x 50; 2.95					

Cap ( $\mu$ F)	450				
	20	22	25	30	35
56	20 x 25; 0.58				
68	20 x 30; 0.67	22 x 25; 0.68			
82	20 x 35; 0.76	22 x 30; 0.82			
100	20 x 35; 0.84	22 x 35; 0.90	25 x 25; 0.92		
120	20 x 40; 0.94	22 x 35; 1.02	25 x 30; 1.04	30 x 25; 1.07	
150		22 x 40; 1.12	25 x 35; 1.19	30 x 30; 1.23	
180		22 x 50; 1.26	25 x 40; 1.33	30 x 30; 1.38	
220			25 x 45; 1.51	30 x 35; 1.56	35 x 30; 1.58
270			25 x 50; 1.65	30 x 40; 1.80	35 x 35; 1.81
330				30 x 45; 2.02	35 x 35; 2.05
390				30 x 50; 2.24	35 x 40; 2.27
470					35 x 45; 2.55

↑ リプル電流 Ripple Current A r.m.s./120Hz-85  
↑ ケースサイズ Case Size D<sup>±1</sup> × L<sup>±2</sup>(mm)