



FEATURES

- *Power factor correction up to 0.99, meeting IEC61000 -3-2(EN61000-3-2)
- * 85 to 264VAC universal input
- * High efficiency up to 85%
- * Low EMI, meeting FCC B, CISPR B
- * Low cost, Type open frame,cover
- *RoHS correspond

SAFETY STANDARDS

- UL60950-1 Recognized
- CSA22.2 No.60950-1 Certified (cUL)
- EN60950-1 (NEMKO Certified)
- CE mark (LVD only)



APPLICATIONS

- *Data/information processing equipment
- *FA control equipment
- *Measuring, inspection and testing equipment
- *Communication equipment
- *Optical equipment

*Peak Loads (for Motor Drive, Lamp) *6

PSW100 SPECIFICATIONS

ITEM		PSW100-15	PSW100-24	PSW100-36	PSW100-48
1	Rated output DC voltage	15V	24V	36V	48V
2	Rated output DC current (Peak *6)	6.7A(-)	4.2A(7.1A)	2.8A(4.7A)	2.1A(3.5A)
3	Maximum output power (Peak *6)	100.5W(-)	100.8W(170.4W)	100.8W(169.2W)	100.8W(168.0W)
4	Efficiency (120/230VAC, TYP)	*1 79%/80%	80%/81%	81%/82%	82%/83%
5	Maximum ripple noise	150mVpp	150mVpp	250mVpp	250mVpp
6	Over current protection	*3 7.1A ~	7.5A ~	5.0A ~	3.7A
7	Over voltage protection	*4 17.3V ~	27.6V ~	41.4V ~	55.2V ~
8	Input voltage range	85V ~ 264VAC			
9	Input frequency range	47Hz ~ 63Hz			
10	Input current	*1 1.4A (100VAC), 0.9A(230VAC)			
11	Inrush current	*2 20Apk MAX (120VAC), 40Apk MAX (240VAC)			
12	Adjustable voltage range	*1 ±5% MIN			
13	Hold-up time	*5 20ms MIN			

NOTES

- *1 When maximum output is worked
- *2 When cold start works with rated voltage at 25°C ambient temperature
- *3 Recovers automatically
- *4 Recovers on input again
- *5 When maximum output is worked, after last AC line peak
- *6 (Peak) : Peak Loads for 10 seconds or less are acceptable.

PSW100 GENERAL SPECIFICATIONS

ITEM		
1	Maximum line / load regulation	±0.5%
2	Voltage tolerance ratio	±3% at line, load, time, temperature
3	Operating temperature	-10 ~ 60°C (Refer to Output derating)
4	Operating humidity	30 ~ 90%RH (Non condensing)
5	Storage temperature	-30 ~ 85°C
6	Storage humidity	10 ~ 95%RH (Non condensing)
7	Cooling	Convection or forced air cooling (Refer to Output derating)
8	Electric strength voltages	Input – Output 3000VAC 1 minute, Input –FG 1500VAC 1 minute, Output –FG 500VAC 1 minute
9	Insulation resistance	100MΩ MIN DC500V 25°C 70%RH Input – Output, input –FG, Output –FG
10	Leakage current	0.5mA MAX (240VAC, 50Hz)
11	Vibration	10 ~ 55Hz 2G (3 directions each 1 hour)
12	Shock	20ms 20G (3 directions each 3times)
13	Safety standards	UL60950-1, CSA60950-1 (cUL), EN60950-1 (NEMKO) Approvals
14	Conduction noise	Meeting FCC Class B, EN55022 Class B, VCCI Class B
15	Mains surge	Meeting EN61000-4-5 Level 3/4KV(CM), 2KV(DM)
16	Dimensions	150(W)92(D)35(H) mm/ 5.91”(W) 3.63”(D) 1.38”(H)
17	Weight	420g / 0.93lb. TYP

PSW100 OUTLINE DRAWING

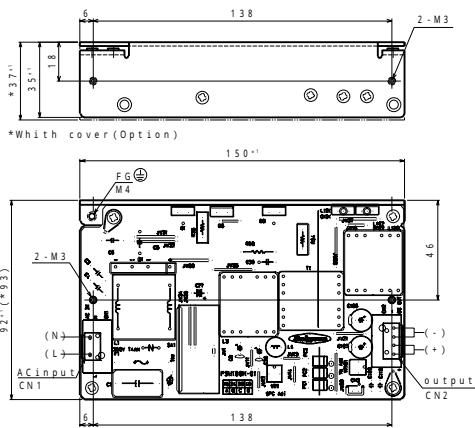

Connectors Used

Part Description	Part Name	Manufacturer	Q.T.Y
CN1 Pin Header (Input side)	B2P3-VH or T7094	JST EMUDEN	1
CN2 Pin Header (Output side)	B4P-VH or T7094	JST EMUDEN	1

Matching Housings and Pins (Not included with the product)

Part Description	Part Name	Manufacturer	Q.T.Y
CN1 Socket Housing	VHR-3N	JST	1
CN2 Socket Housing	VHR-4N	JST	1
(CN1, CN2) Terminal Pins	BVH-21T-P1.1	JST	6

PSW100 OUTPUT DERATING

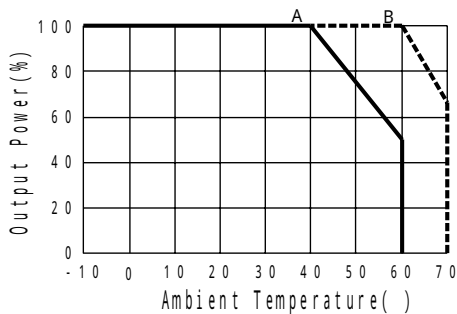

A: Conv. With Cover(option)
 Conv. Open Frame
 B: Recommended minimum air
 Vrocity 0.7m3/minute

Mounting Direction (conv)

