

THC series

125°C 2000時間 標準品
Load Life : 125°C 2000 hours Standard



◆規格表 / SPECIFICATIONS

項目 Item	特性 Characteristics							
カテゴリ温度範囲 Category Temperature Range	-25~+125°C							
定格電圧範囲 Rated Voltage Range	400~450Vdc							
静電容量許容差 Capacitance Tolerance	±20% (20°C, 120Hz)							
漏れ電流 Leakage Current (MAX)	$I=5\sqrt{CV}$ (定格電圧印加5分後) $I=5\sqrt{CV}$ (After 5 minutes application of rated voltage) I=漏れ電流 (µA) C=静電容量 (µF) V=定格電圧 (Vdc) Leakage Current Capacitance Rated Voltage							
損失角の正接 (tan δ) Dissipation Factor (MAX)	<table border="1"> <tr> <td>定格電圧 (Vdc) Rated Voltage</td> <td>400~450</td> </tr> <tr> <td>tan δ</td> <td>0.25</td> </tr> </table>	定格電圧 (Vdc) Rated Voltage	400~450	tan δ	0.25	(20°C, 120Hz)		
定格電圧 (Vdc) Rated Voltage	400~450							
tan δ	0.25							
耐久性 Endurance	125°C中で2000時間定格電圧(リップル重畳)印加後、下記項目を満足すること。 After applying rated voltage with rated ripple current for 2000 hours at 125°C, the capacitors shall meet the following requirements.							
	<table border="1"> <tr> <td>静電容量変化率 Capacitance Change</td> <td>初期値の ±20% 以内 Within ±20% of the initial value.</td> </tr> <tr> <td>損失角の正接 Dissipation Factor</td> <td>規格値の 200% 以下 Not more than 200% of the specified value.</td> </tr> <tr> <td>漏れ電流 Leakage Current</td> <td>規格値以下 Not more than the specified value.</td> </tr> </table>	静電容量変化率 Capacitance Change	初期値の ±20% 以内 Within ±20% of the initial value.	損失角の正接 Dissipation Factor	規格値の 200% 以下 Not more than 200% of the specified value.	漏れ電流 Leakage Current	規格値以下 Not more than the specified value.	
静電容量変化率 Capacitance Change	初期値の ±20% 以内 Within ±20% of the initial value.							
損失角の正接 Dissipation Factor	規格値の 200% 以下 Not more than 200% of the specified value.							
漏れ電流 Leakage Current	規格値以下 Not more than the specified value.							
低温特性 Low Temperature Stability (インピーダンス比) Impedance Ratio (MAX)	<table border="1"> <tr> <td>定格電圧 (Vdc) Rated Voltage</td> <td>400~450</td> </tr> <tr> <td>Z(-25°C)/Z(+20°C)</td> <td>10</td> </tr> </table>	定格電圧 (Vdc) Rated Voltage	400~450	Z(-25°C)/Z(+20°C)	10	(120Hz)		
定格電圧 (Vdc) Rated Voltage	400~450							
Z(-25°C)/Z(+20°C)	10							

◆呼称方法 / PART NUMBER

THC M SN D x L
 定格電圧 シリーズ名 静電容量 静電容量許容差 副記号 端子記号 ケースサイズ
 Rated Voltage Series Capacitance Capacitance Tolerance Option Terminal Code Case Size

◆リップル電流補正係数 /
MULTIPLIER FOR RIPPLE CURRENT

周波数 (Hz) Frequency	60 (50)	120 (100)	300	500	1k	10k ≤
係数 Coefficient	0.80	1.00	1.15	1.20	1.25	1.40

◆副記号 / OPTION

EFC : PET スリーブ、底板なし
PET Sleeve without plate

◆寸法図/DIMENSIONS

●SN[4mm]端子タイプ
SN[4mm]terminal type

端子記号 : SN(錫メッキ)
Terminal code : SN(Tin plating)

(mm)

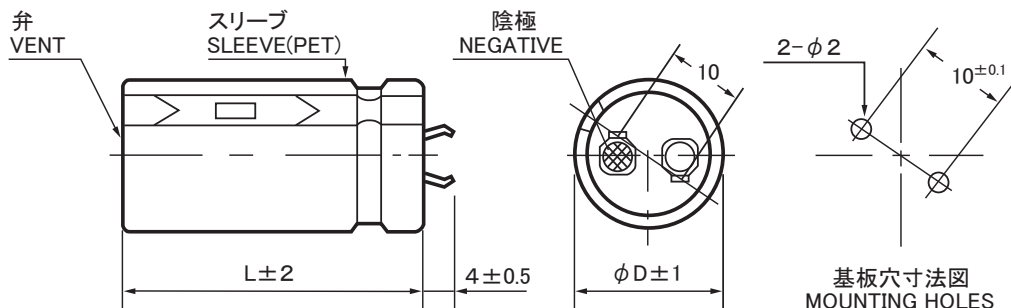

◆標準品一覧表/STANDARD SIZE

Cap.(μF)	400Vdc							
	φ 22		φ 25		φ 30		φ 35	
82	22x25	0.79						
100	22x30	0.91						
120	22x30	0.98	25x25	0.96				
150	22x35	1.14	25x30	1.12				
180	22x40	1.28	25x35	1.28				
220	22x50	1.50	25x40	1.45	30x30	1.35		
270	22x55	1.69	25x45	1.64	30x35	1.55		
330			25x55	1.90	30x40	1.75		
390			25x60	2.09	30x45	1.94	35x35	1.75
470					30x50	2.14	35x40	1.96
560					30x60	2.45	35x45	2.16
680							35x55	2.52
820							35x60	2.72

Cap.(μF)	420Vdc							
	φ 22		φ 25		φ 30		φ 35	
82	22x25	0.79						
100	22x30	0.91						
120	22x30	0.99	25x25	0.96				
150	22x35	1.14	25x30	1.12				
180	22x45	1.34	25x35	1.28				
220	22x50	1.51	25x40	1.45	30x30	1.35		
270	22x60	1.74	25x45	1.64	30x35	1.54		
330			25x55	1.90	30x40	1.74		
390			25x60	2.09	30x45	1.93	35x35	1.74
470					30x55	2.24	35x40	1.95
560					30x60	2.44	35x45	2.15
680							35x55	2.51

Cap.(μF)	450Vdc							
	φ 22		φ 25		φ 30		φ 35	
68	22x25	0.71						
82	22x30	0.82	25x25	0.81				
100	22x35	0.93	25x30	0.94				
120	22x40	1.06	25x30	1.02				
150	22x45	1.21	25x35	1.18				
180	22x50	1.36	25x40	1.33	30x30	1.38		
220	22x60	1.56	25x50	1.55	30x35	1.47		
270			25x55	1.74	30x40	1.66	35x35	1.66
330					30x50	1.94	35x40	1.87
390					30x55	2.14	35x45	2.08
470							35x50	2.30
560							35x55	2.53

ケースサイズ Case Size φD×L(mm) → ↑
リップル電流 Ripple Current (A.r.m.s./120Hz,125°C) → ↑